



**SBFP Series**

## **Single Blade Fire Dampers (Piano Hinge)**

**2 & 4 Hours Fire Integrity Rating**

**For masonry and dry wall application**

### **SPECIFICATION DATA**

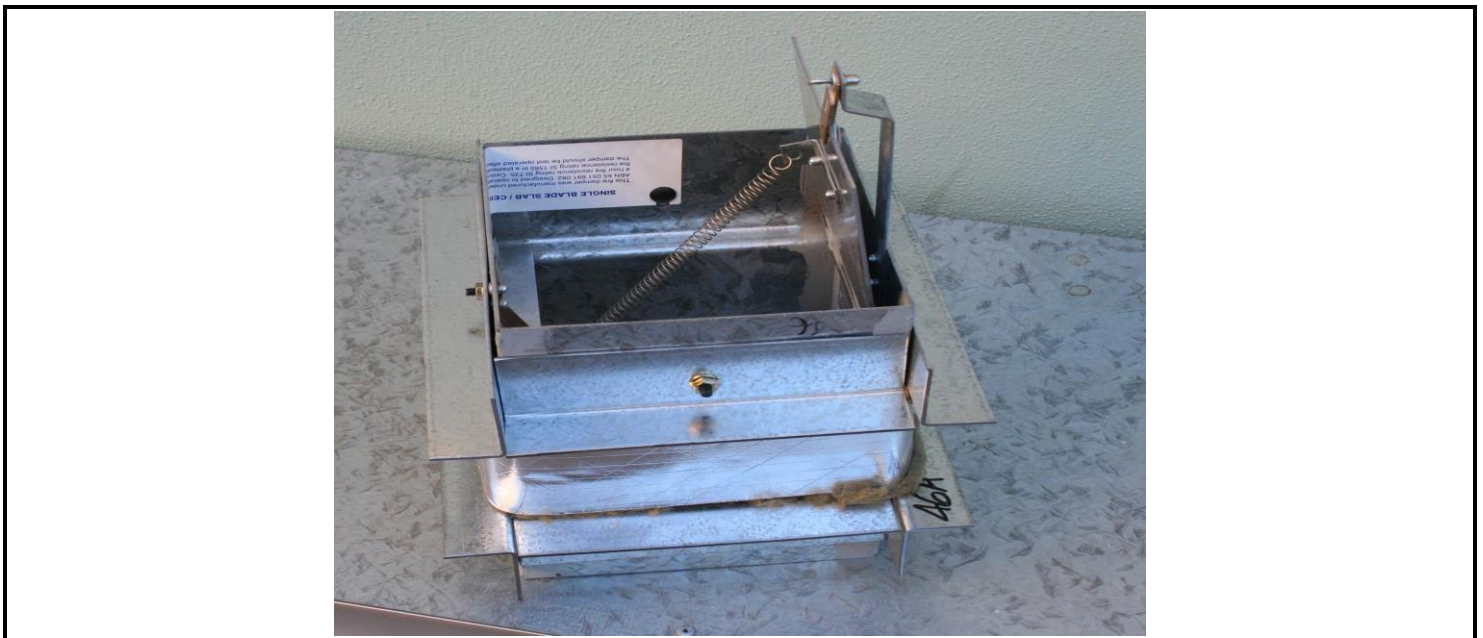

### **General**

The Blendair SINGLE BLADE Fire Damper Series SBFP is a simple and effective damper 'light weight' fire damper, designed to impede the spread of fire and/or combustible products (eg. smoke) through masonry, light weight partition and shaft wall openings to other fire compartments of an air-handling system.

This range of Fire Dampers find its application in commercial building construction where ventilation, heating, cooling or air-conditioning systems are employed.

The design principle is based on a piano hinged, single blade that closes by gravity to form a tightly sealed barrier when a fusible thermal link breaks at a set temperature.

Blendair SINGLE-BLADE (PIANO HINGE) Fire Dampers are certified by Standards Australia and meet AS 1682 and AS 1530 requirements.

### **Features**

- **Simplicity in design**
- **Tight manufacturing tolerances**
- **Sturdy press-formed and fully welded frame construction**
- **Light weight damper easy to install**
- **Suitable for masonry and dry wall applications**
- **Adjustable mounting angles**
- **Suitable for multi-module installation**
- **Spring assisted closure**

# SBFP: SINGLE BLADE FIRE DAMPER

## DESCRIPTION & FUNCTION

The Blendair SINGLE BLADE Fire Damper Series SBFP2 and SBFP4 is a LIGHT-WEIGHT damper, designed to impede the spread of fire and or combustible products (eg. smoke) through wall openings to other fire compartments of an air-handling system.

This range of Fire Dampers finds its application in commercial building construction where ventilation, heating, cooling or air-conditioning systems are employed.

The design principle is based on a piano hinged, SINGLE BLADE that closes by gravity to form a tightly sealed barrier when a fusible thermal link breaks at a set temperature. The damper is securely held in the wall or floor opening by adjustable mounting flanges. Appropriate insulating material is packed into the clearance space between the damper casing and opening to meet Installation Standards.

Single Blade Fire Dampers are tested to AS1530 as required to comply with AS1682 and ASNZ1668.

## MODELS

- **SBFP2:** SINGLE Blade Fire Dampers for **Dry Wall & Shaft Wall** application with **Two (2) Hours Fire Integrity Rating**
- **SBFP4:** SINGLE Blade Fire Dampers for **Masonry Wall & Shaft Wall** application with **Four (4) Hours Fire Integrity Rating**

## GUIDE SPECIFICATION (for the Engineer)

Fire Dampers installed shall be of design and construction as supplied by Blendair which meet the requirements of Australian Standards AS 1682 - Part 1 & 2 and AS 1530.

The damper frame shall be of press-formed and welded galvanised steel construction to minimise distortion during transit and to maintain squareness during installation. The galvanised steel blade shall be pivoted by special S/S piano hinge. The damper must guarantee accuracy and consistent closing operation.

## DAMPER SIZING SPECIFICATIONS

Modules are supplied in the following standard sizes:

**Single Module:** from 150mm x 150mm (min)  
to 600mm x 300mm (max)

**Size Increment:** as required

**Multi Modules:** max 3600mm x 300mm

**Note:** When specifying damper sizes (width and height), quote internal duct dimensions, no deductions are made.

## SHIPPING WEIGHTS (Kg)

Height (mm)	Width (mm)					
	150	200	300	400	500	600
150	6	7	9	10	12	14
200	7	8	10	11	13	15
250	8	9	11	12	14	16
300	9	10	12	13	15	17

**Note:** For weights of multi modules, add total weight by interpolating with above weight table.

## SPECIFICATIONS - Construction

### Materials & Finishes:

- Damper frame, blades and mounting angles made of zinc-coated ("galvanised") steel sheet, complying with AS 1397 with a coating class not less than Z275.
- Damage to the zinc-coating, eg. through welding, is remedied by appropriate cleaning method and application of special 'galvanising' paint.
- Stainless steel version available as OPTION.

### Damper Frame:

Press-formed 1.6 mm galvanised steel, fully welded at all four corners, with 6x12 mm slots punched into casing to allow for variations in wall thickness.



### Damper Blade:

Flat 2.5 mm (nominal) galvanised steel sheet.

## DAMPER ORDERING SPECIFICATION

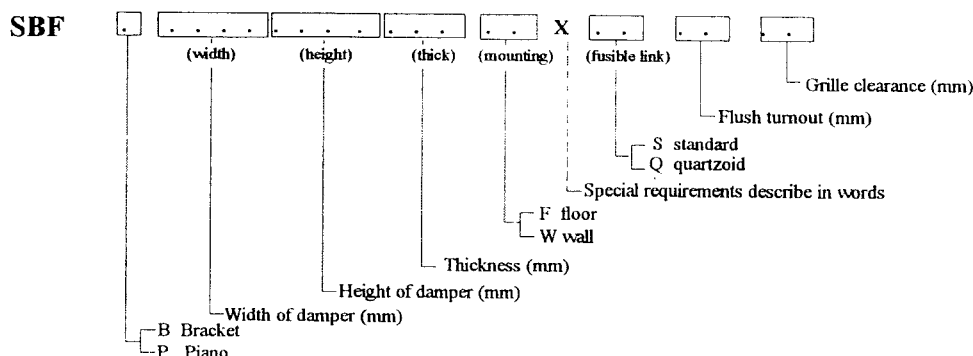

## SBFP: SINGLE BLADE FIRE DAMPER

### Blade Orientation/Location:

#### Horizontal and vertical:

Blade is off-centre pivoted by use of piano hinge and held at top of damper by thermal fire link assembly. Blade closes by gravity, initiated by breaking of thermal fire link.

### Mounting Angles:

Roll-formed 2.0 mm or 2.5 mm 'right-angle' brackets with 6x12 mm rounded slots at 150 mm pitch to allow for variations in wall thickness.

### Blade Hinge:

Blade is pivoted on special stainless steel hinge riveted to blade and damper casing.

### Blade Close-Off Spring:

Stainless steel tension spring is attached to damper blade and casing to assist closing of blade.

### Blade Retainer Clip:

1.0 mm spring bronze material - press-formed clip retains blade in closed position, allowing release from both ends of damper.

### Thermal Fire Link:

The thermal fire link - a 'once only' used link -

- Standard: Fusible Solder Link (70 degree C)
- Optional: Quarzoid Bulb (68 degree C)

Note: Thermal fire link assembly includes interlocked stainless steel rings and bracket which is attached to an tag for duct attachment.

### Access to Thermal Fire Link:

Available from both sides of damper for purposes of blade re-setting or re-fitting of Thermal Fire Link.

### Mounting Hardware:

Zinc plated 1/4 inch cup head bolts, nut and washer for each set of slotted mounting holes in frame & mounting angles.

## SPECIFICATIONS - Technical

### Operation:

Damper closing is initiated by the breaking of the thermal fire link, when temperature in the air stream reaches rated thermal limit. For wall mounted dampers the horizontally held blade will consequently close by gravity and form a tight barrier, impeding the spread of fire and/or combustible products to other compartments of the air-handling system. For floor mounted dampers, the vertically held blade is fitted with a tension spring to assist the blade closing.

### Damper Closing Temperature:

- Standard 'Solder' Fire Link: 70 degree C (nominal)
- Quartzoid Bulb: 68 degree C (nominal)
- Special thermal links or other actuation devices could be fitted by installers, providing they comply with Standards.

### Maximum Air Velocity:

#### IMPORTANT!

It should be avoided to install Fire Dampers near the supply fan which may cause blade flutter and thus excessive wear of blade bearings.

### Recommended Air Velocity:

10.5 m/s (reasonable average)

15.0 m/s (maximum)

*Note: Above values are recommendations from industry survey carried out by CSIRO.*

### Air-Flow Orientation:

Orientation of damper installation should be as per recommended air-flow direction (label affixed to damper frame), so that damper closes with assistance of the air-flow.

## SPARE PARTS

Model No	Description	Qty/Set
BFD-01	Fusible Solder Link (70 degree C)	5
BFD-02	Quarzoid Bulb (68 degree C)	1
BFD-03	Flange Mtg Kit (Bolt & Nut)	50
BFD-27	Electro Thermal Link (Special, refer to Factory)	1

### Standards Approval Listing

SBFP Series SINGLE BLADE Fire Dampers have passed the tests to meet the Leakage and Fire Integrity requirements of AS 1530-Part 4 and AS 1682-Part 1, with the dampers exposed to ~ 1100 degree Celsius for a period of one (1) hour. Tests were carried out at the CSIRO Testing Station.

Copies of SA Certificates may be supplied on request.

Opinion available supporting closure against airflow.

## INSTALLATION

**IMPORTANT:** The installation of Fire Dampers must comply with the requirements of AS 1682, Part 2. Deviation from any Clause of the Standards must be approved by a Regulatory Authority.

### Basic Regulations:

1. Dampers shall be installed in the fully open position only. No intermediate blade position is allowed.
2. Damper frame (casing) must fully penetrate the wall opening.
3. Pivot point of damper blade must be fully contained within the penetrated wall element.
4. Clearance between opening and damper frame must be such to allow adequate of insulating material, PLUS expansion factor for fire situation.

#### Recommended clearance formulae:

**5 mm + 1/2% of linear length dimension (width/height)**

5. The clearance space between the damper and the penetrated wall opening must be fully packed with approved insulating material to prevent free flow of combustible materials (eg. smoke). Material must maintain fire integrity up to 1000 degree C.
6. Mounting Flanges must cover the clearance (2x clearance). Contractor may have to fit larger flanges if clearance exceeds recommended sizes.
7. Ensure that access to damper is provided for maintenance purposes (e.g. access panel in duct).
8. Install damper according to airflow direction of instruction label affixed to casing.

### Other Installation Hints:

1. Remove set of mounting flanges from damper casing.
2. Insert damper into wall opening.
3. Pack clearance space between damper casing and wall opening with insulating material to meet above requirements.
4. Re-fit mounting flanges, nuts & bolts to damper and tighten, ensuring that flanges are butting tight against the wall and that damper is fitted squarely.
5. Ensure that damper closure is not impeded by any obstruction, incorrect installation (eg. twisted, out of square), damage to damper or contamination to blade bearings (eg. building dust).
6. Check proper closing operation.
7. When fitting duct ensure that appropriate damper sleeve connections are used to allow proper duct 'breakaway' in a fire situation (refer AS 1682, part 2 - Appendix B: Examples).
8. Ensure that adequate access panel is fitted to duct to allow easy maintenance to damper.

**Head Office:** Riley Air Control Systems Pty. Ltd.

3/78-80 Bellingara Road  
Miranda NSW 2228  
Phone: (02) 9544 8854  
Fax: (02) 9544 8545  
Email: info@rileyair.com.au

### Installation Examples:

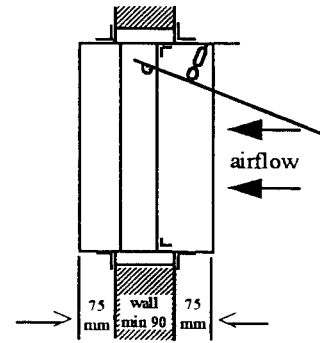

Standard Wall Mounting

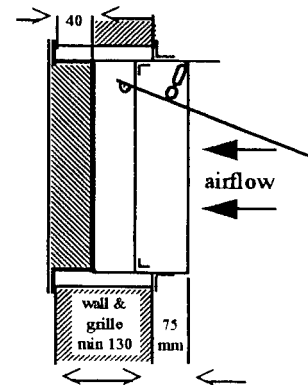

Wall Mounting with Grille

## OTHER DAMPER PRODUCTS

- **Fire Dampers:**  
Multi-Blade Fire Damper, Single Blade Fire Damper, Curtain Fire Damper, Circular Fire Damper, 'Volume'-Fire Damper,
- **Volume Control Dampers:**  
Low Leakage Volume Damper (standard), Ultra Low Leakage Volume Damper, High Performance Volume Damper, Min/Max Damper, Face & Bypass Damper, Zone Damper, Non-Return & Barometric Damper
- **Sub Ducts**
- **Damper Actuators & Accessories:**  
(See separate Product Sheets)