



**RBFD Series**

# **Round Blade Fire Dampers**

**4 Hours Fire Integrity Rating**

**Heavy duty - for wall and floor mounting application**

## **SPECIFICATION DATA**

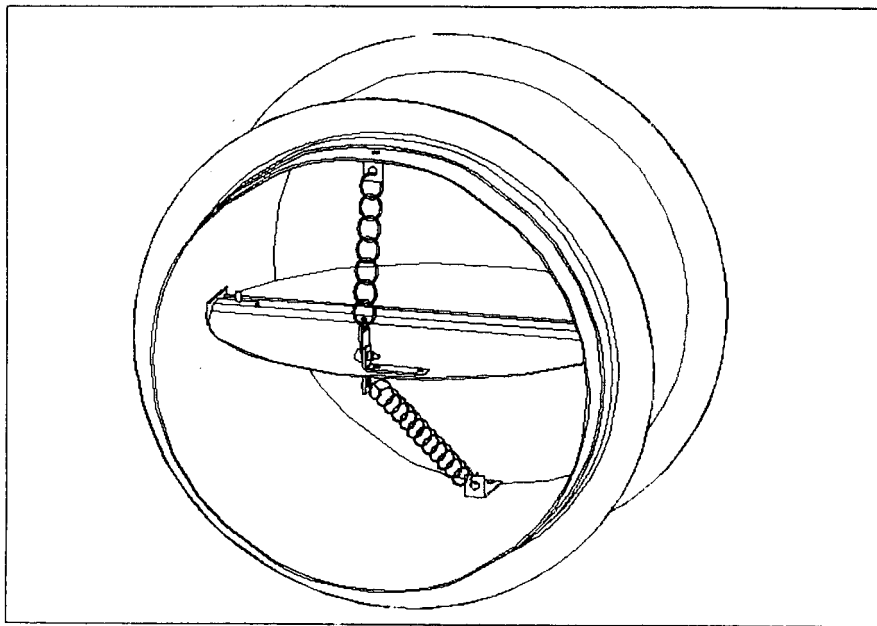

### **General**

The Blendair ROUND Fire Damper Series BRFD is a HEAVY DUTY damper, designed to impede the spread of fire and/or combustible products (eg. smoke) through wall or floor openings to other fire compartments of an air-handling system.

This range of Fire Dampers finds its application in building construction and mining industry where ventilation, heating, cooling or air-conditioning systems are employed requiring circular duct systems.

The design concept is based on a circular blade that pivots on a full-length stainless steel shaft and closes - spring assisted - to form a tightly sealed barrier when a fusible thermal link breaks at a set temperature.

Blendair ROUND Fire Dampers are tested to AS1530 as required to comply with AS1682 and ASNZ1668.

### **Features**

- **Rugged construction**
- **Tight manufacturing tolerances**
- **Rolled casing seam-welded over full length**
- **Non-corrosive blade bearings**
- **Stainless steel version available as option**
- **Suitable for masonry wall and floor mounting application**
- **Adjustable mounting angles**
- **Spring assisted closure**

## RBFD: ROUND FIRE DAMPER

### DESCRIPTION & FUNCTION

The Blendair ROUND Fire Damper Series RBFD is a HEAVY DUTY damper, designed to impede the spread of fire and/or combustible products (eg. smoke) through wall or floor openings to other fire compartments of an air-handling system that uses circular ducting.

This range of Fire Dampers finds its application in commercial building construction where ventilation, heating, cooling or air-conditioning.

The design principle is based on a centre-pivoted blade that closes spring assisted to form a tightly sealed barrier when a fusible thermal link breaks at a set temperature. The damper is securely held in the wall or floor opening by adjustable mounting flanges. Appropriate insulating material is packed into the clearance space between the damper casing and opening to meet Installation Standards.

ROUND Fire Dampers are certified by Standards Australia and meet AS 1682 and AS 1530 requirements.

### MODELS

- **RBFD:** Round Blade Fire Dampers for installation in wall or slab and have been certified for 4 hours rating

### GUIDE SPECIFICATION (for the Engineer)

Round Fire Dampers installed shall be of design and construction as supplied by Blendair which meet the requirements of Australian Standards AS 1682 - Part 1 & 2 and AS 1530.

The damper casing shall be of rolled and welded galvanised steel construction to minimise distortion during transit and to maintain functional operation after installation. The galvanised steel blade shall be pivoted on a full-length S/S shaft. The damper must guarantee accuracy and consistent closing operation.

### DAMPER SIZING SPECIFICATION

Dampers are supplied in the following standard sizes:

**Damper Size:** from 150mm Dia (min)  
to 1200mm Dia (max)

**Size Increment:** as required

**Note:** No deductions are made.

### SHIPPING WEIGHTS (Kg)

Diameter (mm)	Wall/Floor Thickness (mm)			
	100	200	400	600
150	5	6	7	8
200	6	7	9	11
400	11	13	17	20
600	20	22	28	33
800	26	29	36	43
1000	32	36	45	54
1200	44	50	64	77

### SPECIFICATIONS - Construction

#### Materials & Finishes:

- Damper frame, blades and mounting angles made of zinc-coated ("galvanised") steel sheet, complying with AS 1397 with a coating class not less than Z275.
- Damage to the zinc-coating, eg. through welding, is remedied by appropriate cleaning method and application of special 'galvanising' paint.
- Stainless steel version available as OPTION.

#### Casing:

The damper casing is accurately rolled and formed and fully seam-welded to form a solid tube, with 6x12 mm rounded holes punched into casing. It is made of galvanised steel sheet in sizes of 1.6 mm (small dampers to 400 mm dia.) and 2.0 mm (large dampers to 1200 mm dia.).

## DAMPER ORDERING SPECIFICATION

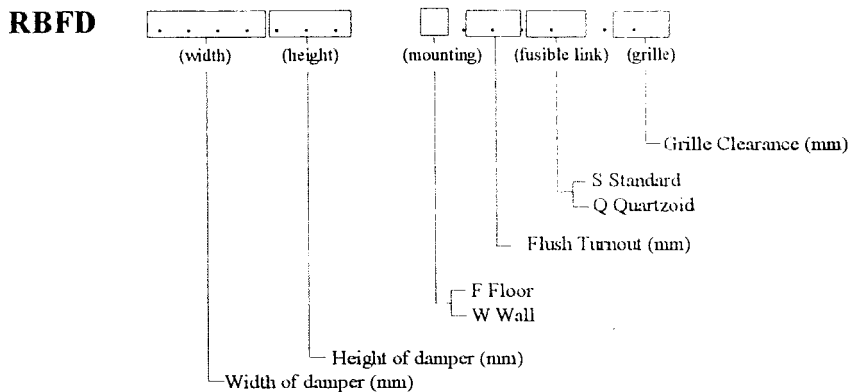

## **RBFD: ROUND FIRE DAMPER**

### **Blade:**

Galvanised steel sheet 1.6 mm (small dampers to 400 mm dia) and 2.0 mm (large dampers to 1200 mm dia).

### **Blade Orientation/Location:**

#### **Horizontal and vertical:**

Blade is centre pivoted and located in centre of casing.

### **Mounting Flanges:**

Rolled 2.0 mm or 2.5 mm 'right-angle' flanges with 6mm rounded holes at 150 mm pitch.

### **Shafts & Bearings:**

Blade is pivoted on full-length 303 stainless steel shaft and bronze bearings.

### **Blade Close-Off Spring:**

Stainless Steel tension spring is attached to damper blade and casing to assist closing of blade.

### **Blade Retainer Clip:**

1.0 mm spring bronze material - Press formed clip retains blade in closed position.

### **Thermal Fire Link:**

The thermal fire link is a 'once only' used

- Standard: Fusible Solder Link (76 degree C)
- Optional: Quartzoid Bulb (68 degree C)

#### **Note:**

1. Thermal fire link assembly is attached to a blade and casing by metal bracket to hold damper in the open position.

### **Access to Thermal Fire Link:**

Available from both sides of damper for purposes of blade re-setting or re-fitting of Thermal Fire Link.

### **Mounting Hardware:**

Zinc plated 1/4 inch cup head bolts, nut and washer for each set of slotted mounting holes in frame & mounting angles.

## **SPECIFICATIONS - Technical**

### **Operation:**

Damper closing is initiated by the breaking of the thermal fire link when temperature in the air stream reaches rated thermal limit.

Horizontally located blades of wall mounted dampers close by gravity and form a tight barrier, impeding the spread of fire and/or combustible products (eg. smoke) to other compartments of the air-handling system.

Vertically located blade of floor mounted dampers close spring assisted.

### **Damper Closing Temperature:**

- Standard 'Solder' Fire Link: 76 degree C (nominal)
- Quartzoid Bulb: 68 degree C (nominal)
- Special Thermal Links or Closing Actuation Devices could be fitted, providing compliance with Standards.

### **Maximum Air Velocity:**

#### **IMPORTANT!**

It should be avoided to install Fire Dampers near the supply fan which may cause blade flutter and thus excessive wear of blade bearings.

### **Recommended Air Velocity:**

10.5 m/s (reasonable average)

15.0 m/s (maximum)

*Note: Above values are recommendations from industry survey carried out by CSIRO.*

### **Air-Flow Orientation:**

Orientation of damper installation should be as per recommended air-flow direction (label affixed to damper frame), so that damper closes with assistance of the air-flow.

## **SPARE PARTS**

<b>Model No.</b>	<b>Description</b>	<b>Qty/Set</b>
BFD-01	Fusible Solder Link (76 degree C)	5
BFD-02	Quartzoid Bulb (68 degree C)	1
BFD-03	Flange Mtg Kit (Bolt & Nut)	50
BFD-27	Electro Thermal Link (Special, refer to Factory)	1

### **Standards Approval Listing**

RBFD Series ROUND Fire Dampers have passed the tests to meet the Leakage and Fire Integrity requirements of AS 1530-Part 4 and AS 1682-Part 1, with the dampers exposed to ~ 1100 degree Celsius for a period of four (4) hours. Tests were carried out at the CSIRO Testing Station.

Copies of SA Certificates may be supplied on request.

## INSTALLATION

**IMPORTANT:** The installation of Fire Dampers must comply with the requirements of AS 1682, Part 2. Deviation from any Clause of the Standards must be approved by a Regulatory Authority!

### Basic Regulations:

1. Dampers shall be installed in the fully open position only! No intermediate blade position is allowed!
2. Damper frame (casing) must fully penetrate the wall or floor opening.
3. Pivot point of damper blade must be fully contained within the penetrated wall element.
4. Clearance between wall opening and damper body (frame) must be such to allow adequate of insulating material, PLUS expansion factor for fire situation. Recommended **clearance formulae:**  
**5 mm + ½% of linear length dimension (width/height)**
5. The clearance space between the damper and the penetrated wall opening must be fully packed with approved insulating material to prevent free flow of combustible materials (eg. smoke). Material must maintain fire integrity up to 1000 degree C.
6. Mounting Flanges must cover the clearance (2x clearance). Contractor may have to fit larger flanges if clearance exceeds recommended sizes.
7. Ensure that access panel are fitted to duct to allow access to damper for maintenance purposes.
8. Install damper according to air-flow direction of instruction label affixed to damper casing.

### Other Installation Hints:

1. Remove one set of mounting flanges from one side of damper.
2. Insert damper into wall opening.
3. Pack clearance space between damper casing and wall opening with insulating material to meet above requirements.
4. Re-fit mounting flanges, nuts & bolts to damper and tighten, ensuring that flanges are butting tight against the wall and that damper is fitted squarely.
5. Ensure that damper closure is not impeded by any obstruction, incorrect installation (eg. twisted, out of square), damage to damper or contamination to blade bearings (eg. building dust).
6. Check proper closing operation.
7. When fitting duct ensure that appropriate damper sleeve connections are used to allow proper duct 'breakaway' in a fire situation (refer AS 1682, part 2 - Appendix B: Examples).
8. Ensure that adequate access panel is fitted to duct to allow easy maintenance to damper.

**Head Office:** Riley Air Control Systems Pty. Ltd.

3/78-80 Bellingara Road  
Miranda  
Phone: (02) 9544 8854  
Fax: (02) 9544 8545  
Email: info@rileyair.com.au

A.B.N. 80 003 437 732

### Installation Example:

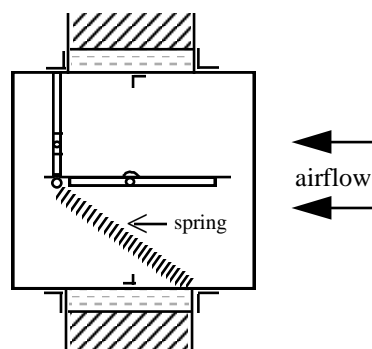

### Standard Wall Mounting

## OTHER DAMPER PRODUCTS

- **Fire Dampers:**  
Multi-Blade Fire Damper, Single Blade Fire Damper, Curtain Fire Damper, Ceiling Fire Damper, 'Volume'-Fire Damper,
- **Volume Control Dampers:**  
Low Leakage Volume Damper (standard), Ultra Low Leakage Volume Damper, High Performance Volume Damper, Min/Max Damper, Face & Bypass Damper, Zone Damper, Non-Return & Barometric Damper
- **Sub Ducts**
- **Damper Actuators & Accessories:**